

CAJA DE PASE

DESCRIPCIÓN:

Las cajas de pase son fabricadas con plancha de acero al carbono recubierta con una capa de **Zinc** en ambas caras, mediante un proceso de Inmersión en Caliente (**Galvanizadas de origen**), según norma **ASTM A-653 CS**. Las cajas de pase son fabricadas con planchas de **0.6mm, 0.9mm, 1.2mm, 1.5mm y 2.0mm** de espesor, pasan por un proceso de corte, troquelado, doblado, para luego ser unido con soldadura de punto, la tapa está sujeta a la caja por una determinada cantidad de autorroscantes, calculado de acuerdo al tamaño de la caja, según norma **ITINTEC370.040**.



CARACTERÍSTICAS ELÉCTRICAS:

Esta caja de uso empotrable cuenta con orificios troquelados de fácil remoción, para la ubicación de tuberías eléctricas o su fijación con tuercas tipo conector, cumplen la función de facilitar la instalación del cableado eléctrico y conductores, así como proteger el cableado eléctrico del ambiente exterior, los elementos o de la desconexión accidental o deliberada.

TIPO	F kg/mm ²	R kg/mm ²	A %	NORMA EQUIVALENTE
ASTM A-653 CS Tipo B	-	28* min	30 min	JIS G 3302 - SGCC - SGHC

- **A: Alargamiento**
- **F: Límite de Fluencia**
- **R: Resistencia a la Tracción.**

Generalmente con recubrimiento G-60 (180gr/m²). También G-40 (120 gr/m²) y G-90 (270gr/m²). * Referencial



FICHA TÉCNICA

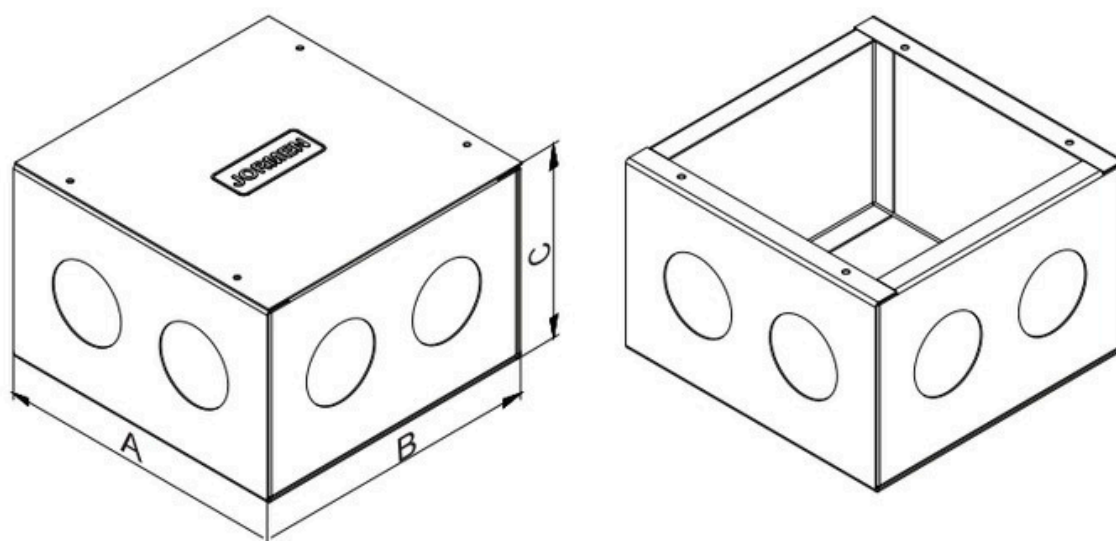

CÓDIGO	A mm(pulg)	B mm(pulg)	C mm(pulg)	E (mm)
CP06310001	100	100	50	0.6
CP06310002	100	100	75	0.6
CP06310003	125	125	75	0.6
CP06310004	150	150	75	0.6
CP06310005	150	150	100	0.6
CP06310006	200	200	75	0.6
CP06310007	200	200	100	0.6
CP06310007	200	200	100	0.6
CP06310008	200	200	150	0.6
CP06310015	250	250	100	0.6
CP06310023	300	300	100	0.6
CP06310030	350	350	100	0.6
CP09310007	100	100	50	0.9
CP09310008	100	100	75	0.9
CP09310009	100	100	100	0.9
CP09310010	100	50	50	0.9



FICHA TÉCNICA

CÓDIGO	A mm(pulg)	B mm(pulg)	C mm(pulg)	E (mm)
CP09310011	125	125	75	0.9
CP09310012	125	125	100	0.9
CP09310013	150	150	50	0.9
CP09310014	150	150	75	0.9
CP09310015	150	150	100	0.9
CP09310016	150	150	125	0.9
CP09310017	150	150	150	0.9
CP12310018	100	100	50	1.2
CP12310019	100	100	75	1.2
CP12310020	100	100	100	1.2
CP12310021	100	50	50	1.2
CP12310022	125	125	75	1.2
CP12310023	125	125	100	1.2
CP12310024	150	150	50	1.2
CP12310025	150	150	75	1.2
CP12310026	150	150	100	1.2
CP12310027	150	150	125	1.2
CP12310028	150	150	150	1.2
CP15310029	100	100	50	1.5
CP15310030	100	100	75	1.5
CP15310031	100	100	100	1.5
CP15310032	100	50	50	1.5
CP15310033	125	125	75	1.5
CP15310034	125	125	100	1.5
CP15310035	150	150	50	1.5
CP15310036	150	150	75	1.5
CP15310037	150	150	100	1.5
CP15310038	150	150	125	1.5



FICHA TÉCNICA

CÓDIGO	A mm(pulg)	B mm(pulg)	C mm(pulg)	E (mm)
CP15313061	293	116	60	1.5
CP15313062	300	200	100	1.5
CP15313064	300	300	100	1.5
CP15313065	300	300	120	1.5
CP15313066	300	300	150	1.5
CP15313067	300	300	200	1.5
CP15313068	300	300	250	1.5
CP15313069	300	540	100	1.5
CP15313070	350	350	100	1.5
CP15313071	370	116	60	1.5
CP15313072	370	370	100	1.5
CP15313073	400	250	100	1.5
CP15313077	400	400	300	1.5
CP15313078	400	400	350	1.5
CP15313079	450	450	150	1.5
CP15313080	450	450	300	1.5
CP15313081	500	300	1500	1.5
CP15313082	500	300	200	1.5
CP15313083	500	500	100	1.5
CP15313084	500	500	250	1.5
CP15313085	550	550	200	1.5
CP15313087	600	500	200	1.5
CP15313088	600	600	100	1.5
CP15313089	600	600	120	1.5
CP15313090	600	600	200	1.5
CP15313090	600	600	250	1.5
CP15313093	650	350	150	1.5
CP15313094	650	650	350	1.5
CP15313095	700	700	100	1.5
CP15313096	700	700	200	1.5
CP15313097	700	700	350	1.5
CP15313098	800	800	150	1.5
CP15313099	800	800	600	1.5

